

Robust CPI design and manufacturing, combined with plenty of thermal margin, results in a GaN SSPA/BUC that is rock-solid, highly efficient and easy to maintain.

CPI Quality

Based on GaN device technology, the SA/SB49KOA series of GaN amplifiers utilizes proprietary RF techniques to provide high linear power and efficiency in small, lightweight, outdoor packages. This compact GaN HPA can be mounted directly at the antenna for maximum efficiency of operation. Full-featured network and serial interfaces are provided to support monitoring and control of the amplifier.

MCC Technology™

With MCC technology, you can be sure that you'll get the most output power out of your HPA, regardless of how many carriers you are using. Without this feature, there would be no telling how far you'd have to back off your output power to achieve a linear signal.

Global Applications

Perfect for LEO/MEO/GEO systems, Satcom on the Move, VSATs, and antenna-mount applications. Meets Electromagnetic Compatibility Directive 2014/30/EU to satisfy worldwide requirements and is CE-marked.

Worldwide Support

Backed by over 40 years of satellite communications experience, and CPI's worldwide 24-hour customer support network that includes more than 20 regional factory service centers.



CPI GaNLink™ 80 W Ka-band GaN SSPA / BUC, Model SA49KOA / SB49KOA

FEATURES:

- 40 watts of linear output power using MCC Technology.
- Exceptional power efficiency
- 30 dB gain adjustment range
- Weatherproof package
- Integrated network and serial M&C interfaces

OPTIONS:

- Integral dual and tri output band BUCs
- Redundancy switching support
- Open BMIP support
- Keyline
- RF output sample port
- IF input sample port

ACCESSORIES:

- AC/DC power converter
- 3 RU controller

Quality Management
System - ISO 9001:2015



GaNLink™ 80 W Ka-band SSPA / BUC Specifications

	SSPA Model SA49KOA	BUC Model SB49KOA
ELECTRICAL SPECIFICATIONS		
RF Output Frequency	27.5 to 30.0 GHz or 29.0 to 31.0 GHz	27.5 to 30.0 GHz or 29.0 to 31.0 GHz (optional dual and triple output band BUCs, in switchable 1 GHz bands)
Input Frequency	27.5 to 30.0 GHz or 29.0 to 31.0 GHz	950 to 1950 MHz or 1000 to 2000 MHz
Spectral Regrowth (1)	at 50 watts (47 dBm) output power, -25 dBc at 1.5 RS offset with 8PSK at 1 MB/second, 2/3 FEC (27.5 to 30.0 GHz)	
Spectral Regrowth (2)	at 40 watts (46 dBm) output power, -25 dBc at 1.0 RS offset with OQPSK at 5 MB/second, 1/2 FEC (29.0 to 31.0 GHz)	
Gain	63 dB min; 69 dB max.	
Gain Stability over temp, constant drive over 24 hrs, constant temp	± 1.5 dB max. ±0.25 dB max.	±2.0 dB max. ±0.25 dB max.
Gain Flatness	±1.75 dB max. full band; ±1.00 dB max. over any 45 MHz	
Small Signal Gain Slope	±0.04 dB/MHz max.	
Gain Adjustment Range	Up to 30 dB (0.1 dB steps)	
Input VSWR (50 Ω)	1.5:1 max.	
Output VSWR (WR28)	1.3:1 max.	
Load VSWR	2.0:1 max. continuous operation; 1.5:1 max. full spec.	
Reference (MUX on IF)	N/A	10 MHz std; 10/50 MHz (specific BUCs only)
Phase Noise (External Reference)	N/A	-120 dBc/Hz at 10 Hz -140 dBc/Hz at 100 Hz -145 dBc/Hz at 1 kHz -150 dBc/hz at ≥10 kHz
Single Sideband Phase Noise	N/A	3 dB better than IESS 308/309 profile
AM/PM Conversion	2°/dB max. full spec.	
Spurious	-60 dB max at Plin (excluding 2 MHz around carrier)	
Group Delay (per 80 MHz)	Linear: 0.03 ns/MHz; Parabolic: 0.003 ns/MHz²; Ripple: 1.0 ns pk-pk	
Noise Power Density	<-150 dBW/4 kHz under 20.2 GHz <-65 dBW/4 kHz, passband	
Prime Power	48 VDC ±10%	
Power Consumption	420 VA typ. at Plin; 600 VA max; 35 VA in mute	
MECHANICAL SPECIFICATIONS		
Dimensions	13.2 x 6.4 x 6.3 inches (336 x 163 x 160 mm), see below or contact CPI for detailed outline drawing	
Weight	16.5 lbs. (7.5 g); 19.8 lbs (9.0 kg), max.	
DC Power Input Connection	Amphenol C016 10C006 000 12	
RF input Connection	2.9 mm female	Type N female
RF Output Connection	WR28 grooved waveguide flange	
M&C Interface	RJ45 cable Multi-pin connector, see outline drawing	
Ethernet		
Serial Interface		
RF Sample Output	SMA female	
IF Sample Output	SMA female	



SMP Division
Satcom Products
tel: +1 669-275-2744
email: satcommarketing@cpii.com
web: www.cpii.com/satcom

For more detailed information, please refer to the corresponding CPI technical description if one has been published, or contact CPI. Specifications may change without notice as a result of additional data or product refinement. Please contact CPI before using this information for system design.

© 2021 Communications & Power Industries LLC. Company proprietary; use and reproduction is strictly prohibited without written authorization from CPI.

GaNLink™ 80 W Ka-band SSPA / BUC Specifications

	SSPA Model SA49KOA	BUC Model SB49KOA
ENVIRONMENTAL SPECIFICATIONS		
Ambient Temperature Operating Non-Operating	-40°C to +60°C -55°C to +85°C	
Relative Humidity	Up to 100% RH condensing	
Altitude	Operating: up to 10,000 feet (3048 m) above sea level, derated 2°C for every 1000 feet above sea level (305 m); Non-operating: up to 50,000 feet (50,000 m) above sea level	
Cooling	Integral forced air	
Shock and Vibration (operating)	Operating: per MIL-STD-810F and MIL-STD-167-1A	
Shock and Vibration (non-operating in shipping container)	MIL-STD-810F516 (Transit Drop); MIL-STD-810F514 (Transportation and Operational Service)	
Weatherproofing	IP66	
Sand and Dust	Will operate in dry and dusty environments typical of arid locations	
Salt Spray	Will withstand salty environments typical of coastal locations	

CPI outline drawing 01-000955 rev A. Please don't use this drawing for system design as it may not be the latest version

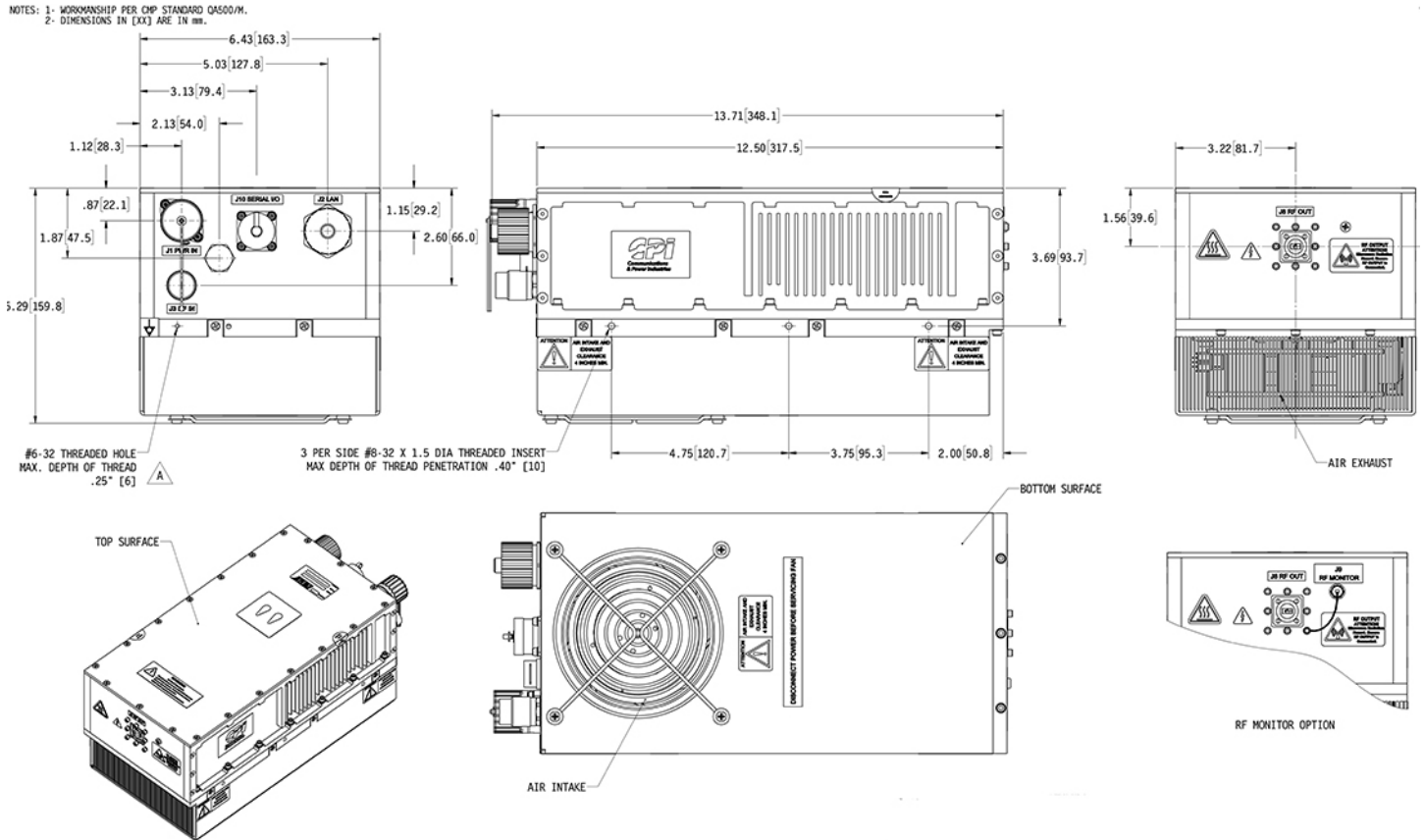

SMP Division
Satcom Products
 tel: +1 669-275-2744
 email: satcommarketing@cpii.com
 web: www.cpii.com/satcom

For more detailed information, please refer to the corresponding CPI technical description if one has been published, or contact CPI. Specifications may change without notice as a result of additional data or product refinement. Please contact CPI before using this information for system design.

© 2021 Communications & Power Industries LLC. Company proprietary; use and reproduction is strictly prohibited without written authorization from CPI.