



OPERATING INSTRUCTIONS

MINIATURE TRAVELING-WAVE TUBES (“MINI-TWTs”)

INTRODUCTION

These Operating Instructions provide basic information for installing and operating CPI MPP’s family of miniature helix vacuum electron devices (traditionally known as helix traveling-wave tubes, or TWTs). Supplementary information is given in the Test Performance Sheet and the product outline drawing. The Test Performance Sheet, which is shipped with the product, contains characteristics and operating values for the individual unit. Inquiries for additional information and requests for copies of these publications should be made to:

Manager, Marketing
Communications & Power Industries, Inc. (CPI)
MICROWAVE POWER PRODUCTS DIVISION
P. O. Box 50750, Mail Stop B-300
Palo Alto, California 94303-0750
Telephone: (650) 846-3133
FAX: (650) 856-0705
E-mail: MPPMarketing@cpil.com

For more detailed product operating procedures in specific equipment, consult the applicable equipment manuals and equipment performance standards. Additional information may be obtained from the equipment manufacturer. Some operational details specified by the equipment manufacturer may vary from those given herein.

WARNING

SERIOUS HAZARDS EXIST IN THE OPERATION OF MICROWAVE DEVICES. BEFORE ATTEMPTING ANY PRODUCT OPERATION, CAREFULLY READ AND UNDERSTAND THE “OPERATING HAZARDS” SECTION FOLLOWING THESE OPERATING INSTRUCTIONS, AS WELL AS THESE INSTALLATION AND OPERATING INSTRUCTIONS. A COPY OF “OPERATING HAZARDS” IS ALSO SHIPPED WITH EACH PRODUCT.

SPECIFIC HAZARDS

CPI as a component supplier can assume no responsibility for any damage or injury resulting from operation of CPI products. These devices must be used with equipment designed to protect personnel against all operating hazards. Installation and operating precautions should be observed, and ratings given in the Test Performance Sheet must not be exceeded.

High Voltage — Normal operating voltages are deadly. The equipment must be designed so the operator cannot come into contact with high voltages. High-voltage circuits and terminals must be enclosed, and interlocking switch circuits must be maintained so they open the primary circuits of the power supply and discharge high-voltage capacitors when access is required.

RF Radiation — Exposure to rf radiation generated by this device during operation may cause serious bodily injury, possibly resulting in blindness or death. Cardiac pacemakers may be affected. Exposure of the human body to microwave radiation in excess of 10 milliwatts per square centimeter can be harmful. For this reason, rf energy must be contained by the waveguides and shielding. If voltages are to be applied when the device is not connected into a waveguide system, the rf input and output flanges should be closed tightly with shielded terminations.

These hazards are specifically described in the Operating Hazards section immediately following these operating instructions. Equipment using these devices must be designed to minimize risk to personnel from these hazards. Equipment manufacturers and users must develop and institute procedures suitable for the particular equipment and specific use to guard against all hazards not eliminated through equipment design.

HANDLING

The product is shipped in an approved package that will protect it from moderate handling abuse. If the outer container shows evidence of being dropped or is punctured, open the package and inspect the unit for damage. Inspect the product when it is removed from the container. If any obvious defects appear, a report should be sent to the factory at once. Any damage during shipment should be reported to the carrier. Handle the device with care during unpacking and installation.

PROTECTIVE MEASURES

These devices must be used in equipment that provides automatic protection as described below. In addition, installation and operating precautions must be observed, and ratings shown within the Test Performance Sheet must not be exceeded. Failure to comply fully with the foregoing may result in product failure, damage, or decreased operating life.

Any product damage or failure resulting from noncompliance with these requirements or which, in CPI's opinion, could have been avoided by compliance with these requirements will void the CPI warranty.

Heater Voltage — Standard CPI mini-TWTs are designed for ac heater voltage, unless otherwise defined by individual product specifications. In the event that square-wave heater voltages are used, the heater voltage should be ac and referenced to the cathode voltage (see Figure 1). In addition, if square-wave heater voltage is used, a true rms voltmeter should be used to set the voltage level. The heater is connected to the cathode internally to make sure the heater and cathode operate at the same dc potential, thereby minimizing noise. Heater voltage is to be applied between the brown and yellow leads only. In the event that the use of a direct-current supply is allowed, the positive side of the supply must be connected to the yellow heater-cathode lead, as shown in Figures 2 and 3. Heater surge current should not exceed approximately twice the steady-state value.

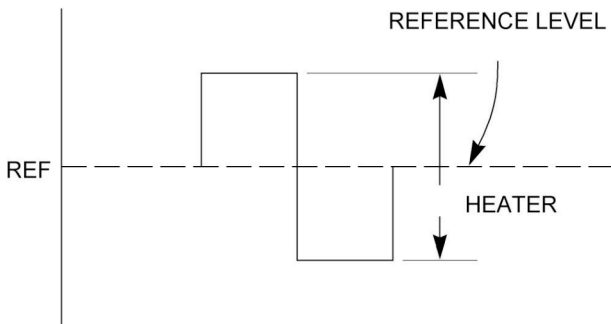

FIGURE 1.
WAVEFORM FOR SQUARE-WAVE HEATER VOLTAGE

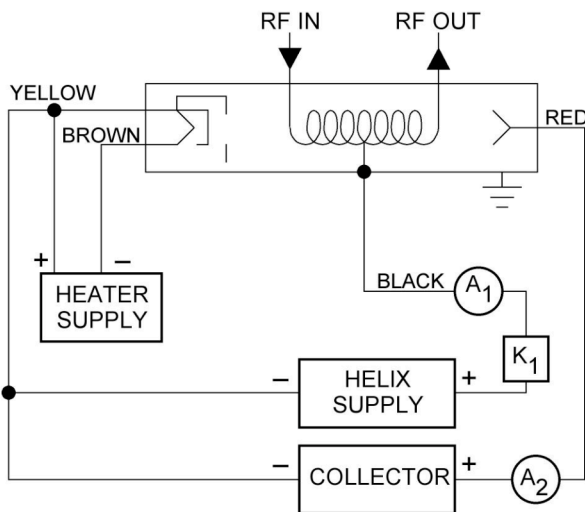
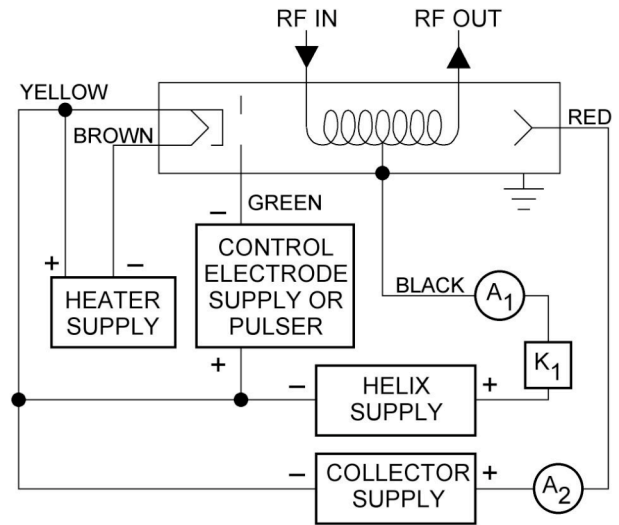

FIGURE 2.
DEPRESSED COLLECTOR, CW MINI-TWT



Note:
A₁ = Helix Current Meter
K₁ = Helix Overcurrent Relay
A₂ = Collector Current Meter

FIGURE 3.
DEPRESSED COLLECTOR, GATEABLE MINI-TWT

Helix (Body) Current — An overcurrent relay, such as K1 in Figure 2, should be part of the power supply and should remove the helix voltage (sometimes referred to as beam or cathode voltage) if the mini-TWT body current exceeds the specified value. The relay trip level should be adjusted to a value of 8.0 mA for most applications or as defined by special requirements. If necessary, contact CPI for recommendations.

Power-Supply Insulation — The mini-TWT body operates at ground potential; therefore, the heater supply must be insulated to withstand the full beam voltage.

Cathode Current Delay — Helix and collector voltages should never be applied to the device until the cathode has reached full operating temperature. The cathode is raised to operating temperature by applying heater voltage. A time-delay relay in the power supply should prevent the application of other voltages until 2 minutes after the heater is turned on, or as defined by the individual Product Specification.

Cooling — Conduction cooling is achieved through the base plate. The base plate must be tightly fastened to a heat sink whose maximum temperature does not exceed 95°C or as defined by the individual product specification. The mounting surface of the heat sink must be machined smooth and flat to ensure maximum contact area with the mini-TWT base plate. The heat transfer to the heat sink is improved by using a thin layer of high-conductivity grease, such as Wakefield Thermal Compound No. 120-8, or equivalent.

Thermal protection may be achieved by attaching a thermal switch to the area at the collector end of the device. The thermal switch should operate at a temperature of 95°C, or as defined by individual product specifications, to remove the

helix voltage. Mini-TWTs are not furnished with thermal switches unless specified by contract.

Focusing — Avoid strong external magnetic fields; they will defocus the electron beam, resulting in decreased output power and possible damage to the device.

VSWR — Voltage standing-wave ratio (VSWR) of the input source and output load should not exceed 4:1 within the operating frequency range of the device. Input and output VSWRs of 1.5:1 or less are required for full specification performance. VSWRs of up to 10:1 are permitted outside the operating frequency range with no damage to the device.

RF Leakage — External leakage should be prevented by making tight rf input and output connections. Under certain tuning conditions, regeneration or oscillation can occur if rf energy from the output line or radiation from the antenna reaches the input cavity because of faulty rf connections, leaky cable, or inadequate shielding. RF radiation is hazardous. See Operating Hazards section.

OPERATION

WARNING

DO NOT ATTEMPT TO OPERATE THIS DEVICE UNTIL IT HAS BEEN DETERMINED THAT ALL PRECAUTIONS HAVE BEEN TAKEN TO PROTECT PERSONNEL FROM ALL HAZARDS. PROTECTIVE DEVICES SUCH AS SHIELDS AND INTERLOCKING SWITCH CIRCUITS MUST BE IN OPERATION. REREAD AND COMPLY WITH ALL PRECAUTIONS AND PROCEDURES SPECIFIED IN THE "OPERATING HAZARDS" SECTION.

WARNING

RF RADIATION — THIS DEVICE IS DESIGNED TO PRODUCE HIGH-ENERGY RF RADIATION, ESPECIALLY IN THE MICROWAVE REGION. EVEN LOW LEVELS OF RF RADIATION CAN BE HAZARDOUS TO HUMAN HEALTH. PRECAUTIONS MUST BE TAKEN TO PREVENT EXPOSURE OF PERSONNEL TO THE STRONG RF FIELDS GENERATED BY THIS DEVICE. RF RADIATION DUE TO LEAKAGE AT THE WAVEGUIDE FLANGE SHOULD BE PREVENTED BY MAKING TIGHT RF INLET AND OUTPUT CONNECTIONS. NEVER OPERATE THIS DEVICE WITHOUT HAVING AN APPROPRIATE ENERGY-ABSORBING LOAD ATTACHED. NEVER LOOK INTO AN OPEN WAVEGUIDE OR ANTENNA WHILE THIS DEVICE IS ENERGIZED.

Preliminary Check — Check the following conditions before applying voltages to the device:

1. Heater, cathode, control electrode, collector, and rf connections are made correctly.
2. Mini-TWT body is grounded.
3. All protective circuits are operational.
4. Device is secured to an adequately cooled heat sink.

Application of Voltages — Recommended operating voltages and currents are given on the product nameplate and are to be applied in the following sequence:

1. **Heater.** Unless otherwise defined by the individual Product Specification, typically allow 2 minutes for cathode warm-up after the application of heater voltage.

WARNING

HIGH VOLTAGE — VOLTAGES REQUIRED FOR OPERATION OF THIS DEVICE ARE EXTREMELY DANGEROUS TO LIFE; EQUIPMENT MUST BE DESIGNED WITH PROTECTIVE INTERLOCK CIRCUITS TO MAKE PHYSICAL CONTACT WITH THESE VOLTAGES IMPOSSIBLE. SEE "OPERATING HAZARDS" SECTION.

2. **Control Electrode Voltage.** The control electrode, when provided, is zero-bias negative-going and is measured relative to the cathode. Beam current cutoff occurs when the control voltage is driven to a negative value (see the Test Performance Sheet). The device is at full beam current when the control electrode is at cathode potential. The control electrode may be used as a blanking or as a pulse-control element.
3. **Collector Voltage.** The collector voltage (E_k) is operated depressed (not at chassis ground) and is measured relative to the cathode.
4. **Helix Voltage.** The helix voltage (E_w) must be preset to the required nameplate value before it is applied to the TWT.

CAUTION

THE HELIX AND COLLECTOR VOLTAGES MAY BE APPLIED CONCURRENTLY, PROVIDING THAT THE RATIO OF THE COLLECTOR VOLTAGE TO THE HELIX VOLTAGE IS NEVER LESS THAN THE INDICATED OPERATING RATIO. IT MUST BE ENSURED THAT APPROXIMATELY 90 PERCENT OF THE ELECTRON-BEAM CURRENT REACHES THE COLLECTOR WHEN HELIX VOLTAGE AND COLLECTOR VOLTAGE ARE APPLIED. THE COLLECTOR IS DESIGNED TO DISSIPATE THE BEAM POWER. THE HELIX CANNOT WITHSTAND HIGH HEAT DISSIPATION AND CAN BE DESTROYED IF FULL BEAM CURRENT REACHES IT. PERIODIC-PERMANENT-MAGNET-FOCUSED MINI-TWTs FOCUS CORRECTLY ONLY AT VOLTAGES NEAR THE NORMAL OPERATING VOLTAGE.

Removal of Voltages — All voltages should be removed in the reverse order from the application of voltages.

RETURNED PRODUCT FORM

Before any product is returned for repair and/or adjustment, written authorization from CPI for the return and instructions

as to how and where the product should be shipped must be obtained. The product type and serial numbers and a full description of the circumstances giving rise to the warranty claim should be included. Such information will help establish the cause of failure and expedite adjustment or repair. For this purpose, a Returned Product Form is shipped with each product.

TRANSPORTATION AND STORAGE

Use the original packing case for both transportation and storage of the product when it is not in service.

CAUTION

*PRODUCT STORAGE SHELVES MUST BE MADE OF
NONMAGNETIC MATERIALS.*